

norweco[®]
HYDRO-KINETIC[®]

**WASTEWATER TREATMENT SYSTEM
MODELS 3780L THROUGH 5670L
WITH 4 CHAMBER TREATMENT TANK**

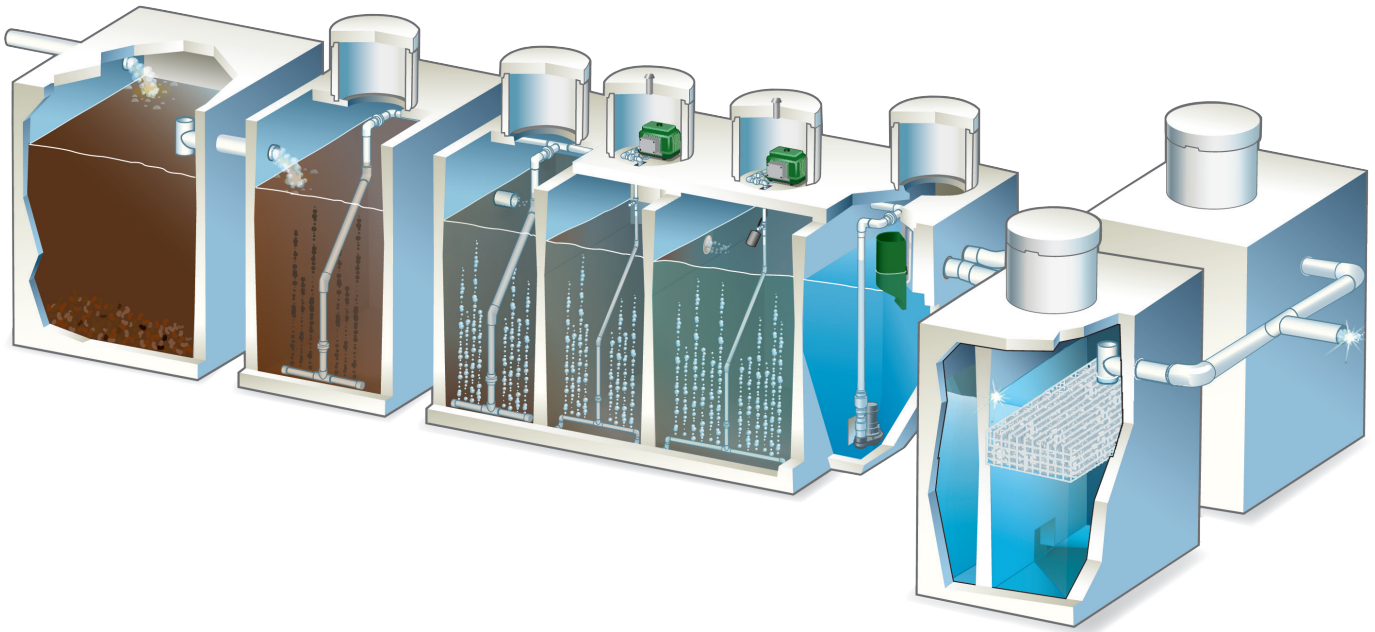

INSTALLATION AND OPERATION MANUAL

Hydro-Kinetic® Installation and Operation Instructions

Wastewater enters the pretreatment chamber to precondition the waste before it flows into the anoxic chamber. Once in the anoxic chamber, facultative anaerobes digest organic matter. Flow then enters the aeration chamber where aerobic bacteria biologically convert the waste into stable substances and oxidize ammonia into nitrite and nitrate. Following aeration, liquids flow to the clarification chamber where gravity settles out biologically active material. A recirculation pump in the clarifier transfers a portion of the wastewater back to the anoxic chamber where nitrogen compounds are converted to harmless nitrogen gas. From the clarifier, treated liquids pass through the flow equalization devices and into the disposal system. Effluent passes through the Bio-Film Reactors for final treatment.

The Hydro-Kinetic system is certified to BNQ Standard 3680-600 Class B-IV, D-I, N-I and BNQ Standard 3680-910 Class III, averaging effluent quality of 3.0 mg/L CBOD, 2.0 mg/L TSS, 67% Nitrogen removal and 2,200 CFU/100 ml fecal coliform. The Hydro-Kinetic system with Phos-4-Fade filter is certified to BNQ Standard 3680-600 Class B-IV, D-I, N-I, P-II and BNQ Standard 3680-910 Class IV, averaging effluent quality of 3.0 mg/L CBOD, 2.0 mg/L TSS, 67% Nitrogen removal, 0.14 mg/L Total Phosphorus and 2,200 CFU/100 ml fecal coliform. The Hydro-Kinetic system with UV disinfection is certified to BNQ Standard 3680-600 Class B-IV, D-III, N-I and BNQ Standard 3680-910 Class V, averaging effluent quality of 3.0 mg/L CBOD, 2.0 mg/L TSS, 67% Nitrogen removal and 2 CFU/100 ml fecal coliform. The Hydro-Kinetic system with activated alumina filter and UV disinfection is certified to BNQ Standard 3680-600 Class B-IV, D-III, N-I, P-II and BNQ Standard 3680-910 Class IV & V, averaging effluent quality of 3.0 mg/L CBOD, 2.0 mg/L TSS, 67% Nitrogen removal, 0.14 mg/L Total Phosphorus and 2 CFU/100 ml fecal coliform.

Before You Start

Installation procedures, equipment and personnel should always comply with applicable safety regulations as well as all federal, state and local codes. The Hydro-Kinetic system must be installed by an authorized representative of Norweco according to these instructions to insure safe, reliable and efficient operation. Carefully unpack and inspect the system components. Make sure you have received all components in good condition. Read all instructions before beginning installation. The Hydro-Kinetic system components include:

1. Service Pro Model 801P Control Center
2. Model A150 Air Pumps (with power wire junction box) (2 required)
3. Alarm Float (with alarm wire junction box)
4. Flow Equalization Devices (2 required)
5. Primary Recirculation Assembly
6. Model SD103 Recirculation Pump
7. Intermediate Recirculation Assembly
8. Diffuser (2 required)
9. Mixing Bar
10. Mixing Bar Drop Pipe Assembly
11. Diffuser Drop Pipe Assembly (2 required)
12. Primary Air Assembly (2 required)

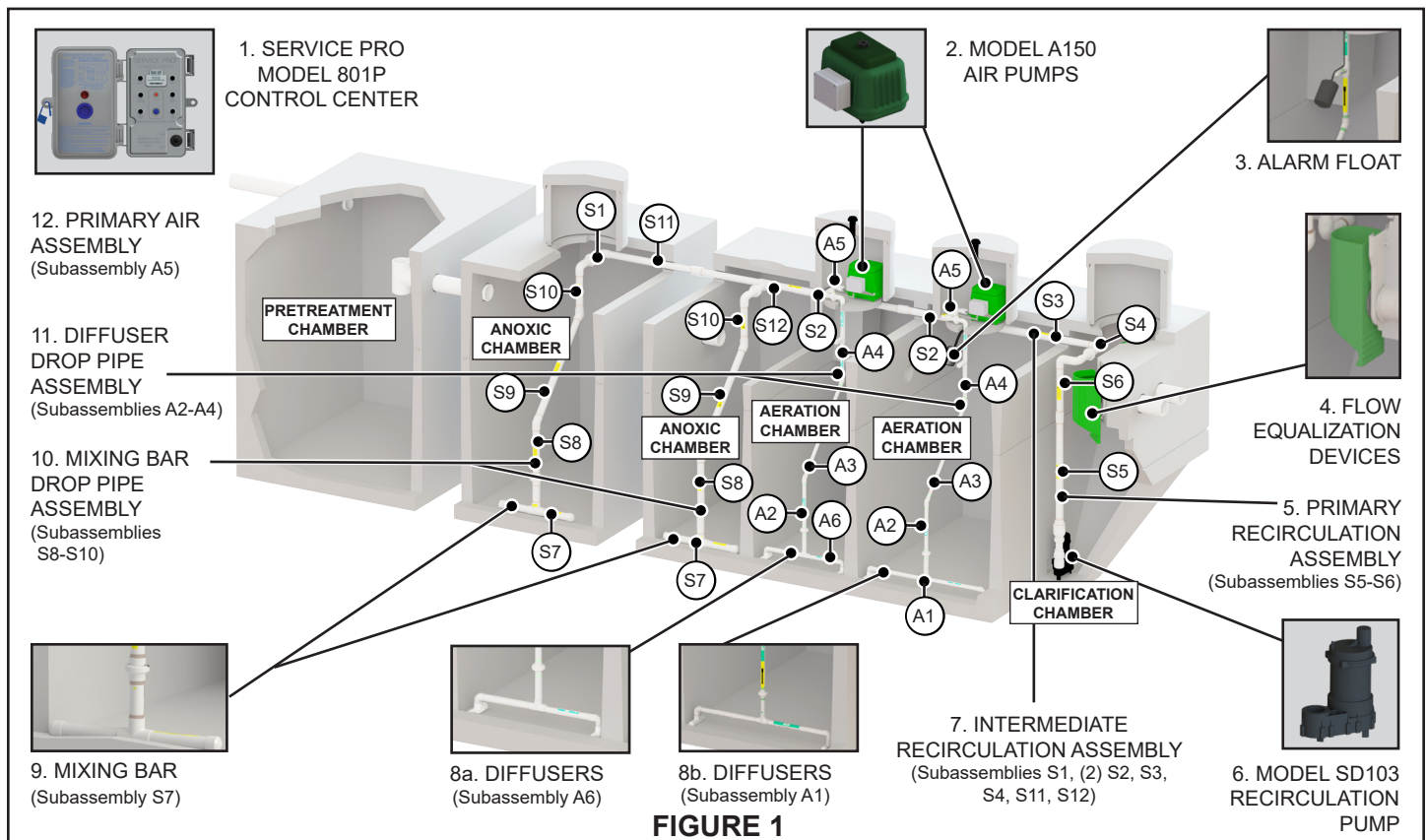

Pre-Delivery Tank Preparation

The Hydro-Kinetic tank equipment package contains some components that are cast-in the tank during the manufacturing process, and other components that are installed after the casting process is complete. Some components of the intermediate recirculation assembly provided in the equipment package must be installed in the tank prior to delivery. In addition, the distributor will need to provide a pretreatment outlet tee, an aeration chamber inlet elbow and Bio-Film Reactor outlet tees if these components have not been cast in place. Norweco recommends assembling all of these components, as well as the Bio-Film Reactor elements, before the tanks are delivered to the installation site. Install components according to the following steps:

1. For a one-piece tank, solvent weld the 4" Schedule 40 PVC pretreatment outlet tee to the coupling that was cast-in the outlet of the pretreatment chamber (distributor to provide). Solvent weld the 4" Schedule 40 PVC aeration chamber transfer elbow into the coupling cast-in the inlet of the first aeration chamber (distributor to provide).
2. For all systems, begin in the external anoxic chamber and solvent weld subassembly S1 into the pipe provided with subassembly S11 that does not have a coupling glued onto one end. Dry fit the coupling on the second section of pipe in subassembly S11 to the first pipe. Do not glue subassembly S11 at this time. The pipes in this subassembly will need to be trimmed to length when the tanks are set.
3. Slide the first subassembly S2 through the opening cast in the wall between the first and second aeration chambers. The coupling side of this subassembly S2 should be oriented towards the outlet side of the tank. Lower the second subassembly S2 into the first aeration chamber and solvent weld the pipe side of the subassembly into the coupling cast into the inlet of the first aeration chamber. Solvent weld the pipe from the second subassembly S2 into the coupling from the first subassembly S2.
4. Starting in the second aeration chamber, pass subassembly S3 through the wall into the clarification chamber. Solvent weld the coupling on subassembly S2 to subassembly S3. See Figure 2.
5. Inside the clarification chamber, solvent weld the elbow from subassembly S4 to the pipe from subassembly S3. The elbow from subassembly S4 should be oriented as shown in Figure 2, with the short stub of pipe parallel to the floor and ceiling of the tank.
6. Place the Bio-Film Reactor elements into the media chamber of the Bio-Film Reactor tanks. They will rest on the support rib cast into the media chamber. The Bio-Film Reactor elements should be installed with the media service hatch oriented toward the middle of the tank and facing up. See Figure 3.

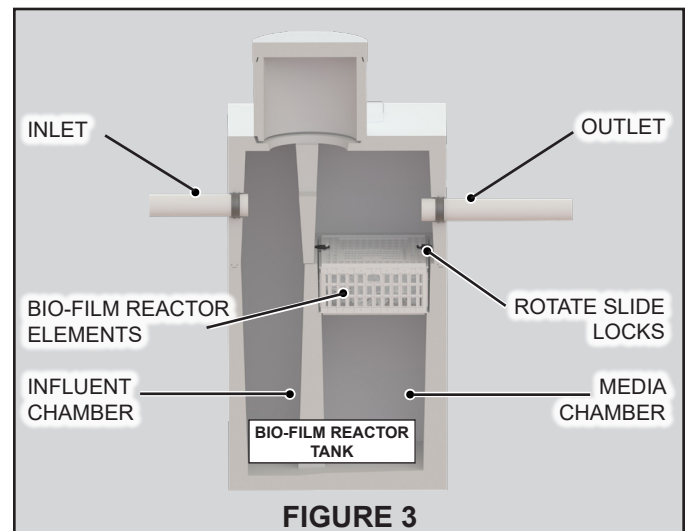
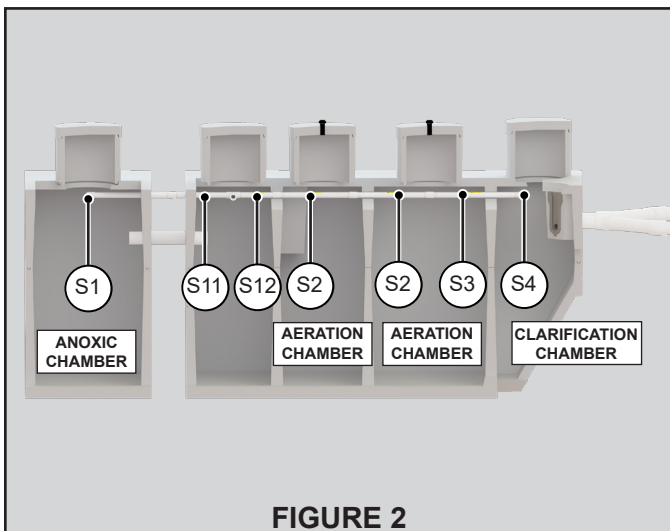

7. Using the universal tool, rotate the two slide locks on each Bio-Film Reactor element so that they lock into the recesses cast into the tank.

Tank Delivery and Setting

1. When installing a Hydro-Kinetic system, first check the length, width and depth of the excavation. Insure the excavation is long enough to allow at least 1' between the pretreatment and anoxic tanks, at least 1' between the anoxic and treatment tanks, and at least 2' between the treatment tank and the Bio-Film Reactors for installation of the interconnect plumbing and backfill between the tanks. The excavation should have sufficient overdig to allow for a minimum of 6" clearance around the entire perimeter of the system. Additional overdig will be required on deep installations or where unstable soil conditions exist. Safe working conditions must be established and maintained during the entire installation procedure.

2. Prepare the excavation to the appropriate depth based on the elevation of the building sewer line. Concrete systems should have a maximum burial depth of 42" below grade to top of the tank. HDPE systems should have a maximum burial depth of 36½" below grade to top of the tank. Allow ⅛" of fall per foot from the building to the system. Fall through the system is 5" from inlet invert to outlet invert. Therefore, the outlet line from the system must be installed 5" lower than the inlet sewer line. The bottom of the excavation must be level and smooth. A 4" layer of gravel, sand or fine crushed stone should be installed and leveled to within ¼" from side to side and end to end.
3. Using extreme caution, place the pretreatment tank into the excavation. Place the anoxic tank in the excavation allowing at least 1' between the pretreatment tank and the anoxic tank. Place the treatment tank in the excavation allowing at least 1' between the anoxic tank and the treatment tank. Place the Bio-Film Reactors in the excavation allowing at least 2' between the treatment tank and the Bio-Film Reactor tanks. Insure tanks are installed square and level.
4. Connect the building sewer line to the pretreatment chamber inlet. The inlet line must be laid continuously and unspliced from the tank to undisturbed earth beyond the limits of the tank excavation.
5. Install 4" Schedule 40 PVC pipe (distributor to provide) between the pretreatment tank and the anoxic tank. If the pretreatment tee was not installed prior to tank delivery, it should be solvent welded to the transfer pipe inside the pretreatment tank at this time as shown in Figure 1.
6. Install 4" Schedule 40 PVC pipe (distributor to provide) between the anoxic tank and the treatment tank.
7. Install 4" Schedule 40 PVC pipe and fittings (distributor to provide) between each treatment tank outlet coupling to the corresponding Bio-Film Reactor tank inlet for the interconnect plumbing.
8. Connect the discharge sewer line to the Bio-Film Reactor tank outlets continuously and unspliced from the tee combining the Bio-Film Reactor tank outlets to undisturbed earth beyond the limits of the tank excavation. If using a one-piece tanks, insert the outlet plumbing through tank outlet seals, leaving 4" to 6" protruding inside the tanks. Solvent weld the 4" Schedule 40 PVC outlet tees (distributor to provide) to the outlet plumbing.
9. Lower subassembly S12 into the second anoxic chamber and solvent weld the pipe on the subassembly into the coupling cast into the outlet of the anoxic chamber. The tee and short stub of pipe should be parallel to the floor and ceiling of the tank as shown in Figure 2.
10. Solvent weld subassembly S11 from the first anoxic chamber to subassembly S12 from the second anoxic chamber as shown in Figure 2. Subassembly S11 will need to be trimmed to length. Solvent weld the two sections of subassembly S11 together. The elbow on subassembly S1 should be oriented as shown in Figure 2, with the short stub of pipe parallel to the floor and ceiling of the tank.
11. Install risers as required to bring the access covers to grade.

Plant Wiring and Control Center Installation

1. Electrical work must be performed in accordance with the latest edition of the National Electrical Code as well as applicable local codes.
2. All electrical service cable used with the Hydro-Kinetic system must be UL and CSA approved, type UF, #14/2 AWG minimum and must have a full-size center ground. Larger cable is required if the length of the underground service is greater than 80 feet. Consult your electrician for details.
3. An approved cable must be installed from the air pumps to the junction box provided for connection to the control center. If installing the air pumps in a location other than the aeration chamber risers, insure the air lines are no more than 75' in length and the air pumps are protected from the elements in a clean, dry, well-ventilated area and proceed to step 6.
4. Inspect the power cable entrance in the side of the first aeration riser. Remove any sharp edges or flash. Insert the free end of the power cable through the shorter segment of a pre-formed ½" conduit ell (2' by 1'), then into the power cable entrance of the aeration riser. Guide the power cable into the riser. Pull enough cable through the riser to reach 36" above the riser top. Coil and secure the cable in the aeration riser so that it will not hang down into the tank. Repeat this step for the second aeration riser.
5. Lay the conduit ells with cable directly across the top and down the tank side. Do not allow the power cables to be laid across the end of the tank or any removable access cover. Seal the connections between the conduits and the aeration risers with mortar or approved sealant.
6. A third underground cable must be installed unspliced from the Service Pro control center into the clarification chamber riser to supply power to the recirculation pump.

7. Inspect the power cable entrance in the side of the clarification riser. Remove any sharp edges or flash. Insert the free end of the power cable through the shorter segment of a pre-formed ½" conduit ell (2' by 1'), then into the power cable entrance of the clarification riser. Guide the power cable into the riser. Pull enough cable through the riser to reach 36" above the riser top. Coil and secure the cable in the clarification riser so that it will not hang down into the tank.
8. Lay the conduit ell with cable directly across the top and down the tank side. Do not allow the power cable to be laid across the end of the tank or any removable access cover. Seal the connection between the conduit and the clarification riser with mortar or approved sealant.
9. Two alarm leads must be installed from the air pump pressure switches to the Service Pro control center. The pressure switches should be wired in series as shown in Figure 9 to allow the activation of either pressure switch to activate the auxiliary alarm. The alarm leads should be #16 AWG minimum and installed in conduit where contact with concrete may occur. **IMPORTANT:** Alarm leads and power leads must always be installed in separate conduits.
10. Two alarm leads must be installed from the high water float switch to the Service Pro control center. The alarm leads should be #16 AWG minimum and installed in conduit where contact with concrete may occur. **IMPORTANT:** Alarm leads and power leads must always be installed in separate conduits. If the air pump will be installed in the aeration riser, the high water and air pump alarm leads should be installed in the same conduit. Properly seal the conduit opening in the riser with mortar or approved sealant.
11. Check the excavation and sewer line trenches to be sure they are free of debris, rocks and any sharp or abrasive objects that could damage electrical cables or alarm leads during backfill or settling.
12. Uncoil the electrical service cables and alarm leads into the excavation and influent sewer line trench. Leave sufficient slack in the cables so they will not be stressed or pulled tight during backfill or settling.
13. Always encase the electrical cables and alarm leads in conduit any time they are above finished grade. Route the conduits and cables as directly as possible to the control center mounting location.

Required Prior to Backfilling

1. For installations where the air pumps will not be located in the aeration risers, install a ¾" Schedule 40 PVC air lines from the air pumps to the system. The air lines should be buried in a trench at a recommended depth of at least 12 inches. Protect the air lines in a casing pipe if heavy loading is anticipated. The air lines must be run into the aeration risers and the openings in the riser sealed with mortar or approved sealant.
2. On the Bio-Film Reactor elements, use the universal tool to insure each of the slide locks are rotated until they are in the furthest extension point possible.

Backfilling

1. The system should be backfilled immediately after sewer lines and underground electrical cables are installed. Fine, loose earth should be used to backfill the tank excavation and sewer line trenches. Be sure it is completely free of rocks, large clumps of earth and construction debris. Use fine granular material when backfilling around electrical cables and conduits. The underground electrical cables should have at least two feet of earth cover. If the proposed finished grade will not permit this coverage, the cables should be installed in approved conduit from the tank to the building foundation. Backfill evenly around the entire perimeter of the tank rather than all at once on each side. Take care to completely fill in the cavity beneath the hopper at the bottom of the clarifier end wall.
2. Final grading should be 6" below the top of each access cover and should slope away from the tank so surface runoff will drain away from the treatment system. Use extreme care in backfilling. Do not allow dirt or mud to enter any part of the treatment system or sewer lines. If dirt or mud enters any portion of the system, it must be removed to insure proper system operation. Removing the dirt or mud may require repeated flushing and tank pumping.
3. Immediately after backfilling, fill each chamber of the treatment system with water to the outlet invert. The water must be free of leaves, mud, grit or any other materials that might interfere with system operation.

Air Pump and Piping Installation

1. Remove the bundle of components labeled "AIR". Attach the smaller diffuser bar A6 to the first subassembly A2 at union as shown in Figure 4. Attach the longer diffuser bar A1 to the second subassembly A2 at union as shown in Figure 4. Securely tighten unions by hand.
2. Solvent each weld subassembly A2 to a subassembly A3 as shown in Figure 4. Insure red arrows are aligned.
3. Solvent each weld subassembly A3 to a subassembly A4 as shown in Figure 4. Insure blue arrows are aligned.

4. Install the smaller diffuser and drop pipe assembly into first aeration chamber by bending the flexible tubing. Lower assembly into the tank until the diffuser bar contacts both the floor and side wall of the tank as shown in Figure 4.
5. Install the longer diffuser and drop pipe assembly into second aeration chamber by bending the flexible tubing. Lower assembly into the tank until the diffuser bar contacts both the floor and side wall of the tank as shown in Figure 4.
6. Remove the air pumps and components from their cartons. If the air pumps will be installed in the aeration chamber risers, install concrete support bases for the air pumps.
7. Install each air pump in the aeration chamber risers on the support bases (or in a clean, dry, well-ventilated area protected from the elements no more than 75' from the tank). Attach each subassembly A4 to each subassembly A5 at union as shown in Figure 4. Securely tighten union by hand.

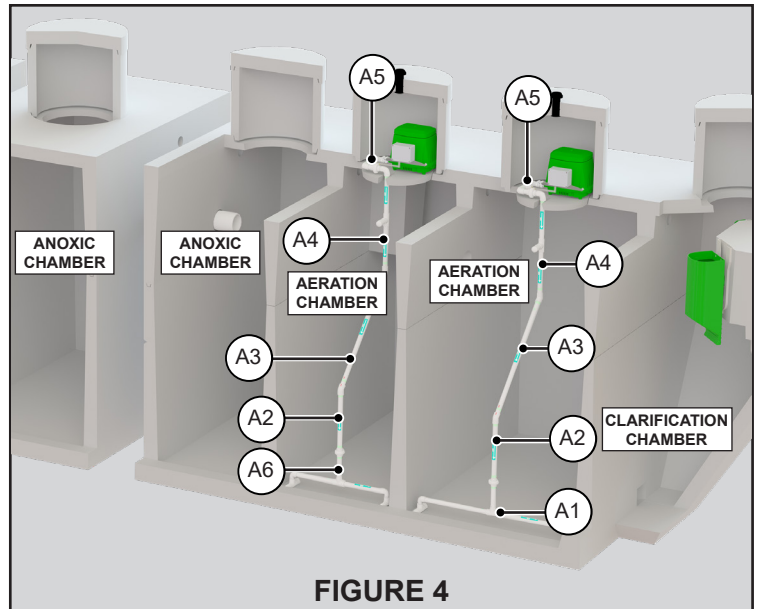

FIGURE 4

8. To wire the air pump female electrical connectors, unscrew the three captive stainless steel screws from the face of the female connector. They will stay in the body of the receptacle. Lift out the rigid internal receptacle body. Unscrew the compression nut on the strain relief connector. Insert the electrical service cable through the compression nut, compression ring and neoprene grommet. Strip the outer insulation back 1¼" on the underground electrical service cable and expose the three individual leads. Use extreme care to be sure the insulation jackets on the individual black and white leads are not scarred or damaged while stripping the outer jacket.

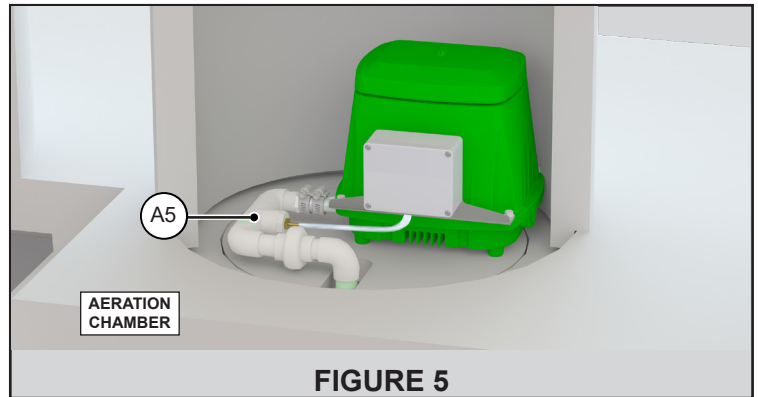

FIGURE 5

9. Strip off the insulation jackets ¼" from the ends of the individual black and white leads. Insert the black lead into the hole adjacent to the brass-colored screw and tighten the screw securely. Insert the white lead into the hole adjacent to the silver-colored screw and tighten the screw securely. Insert the bare copper ground lead into the hole that is adjacent to the green-colored screw and tighten the screw securely. Align the insert key on the receptacle body with the keyway molded into the rubber sleeve. Press the receptacle body into the sleeve and tighten the three stainless steel screws on the face of the connector. Press the grommet into the electrical connector and tighten the compression nut.
10. Plug the male connector on each air pump power cord into the appropriate female connector.

Recirculation Pump and Piping Installation

In the clarification chamber:

1. Thread subassembly S5 into the pump discharge as shown in Figure 7.
2. Solvent weld the coupling on subassembly S5 to subassembly S6. See Figure 7.
3. Attach pump cord to pump discharge assembly (S5-S6) using cable ties provided.
4. Use the discharge plumbing assembly to lower the recirculation pump into the clarification chamber until the

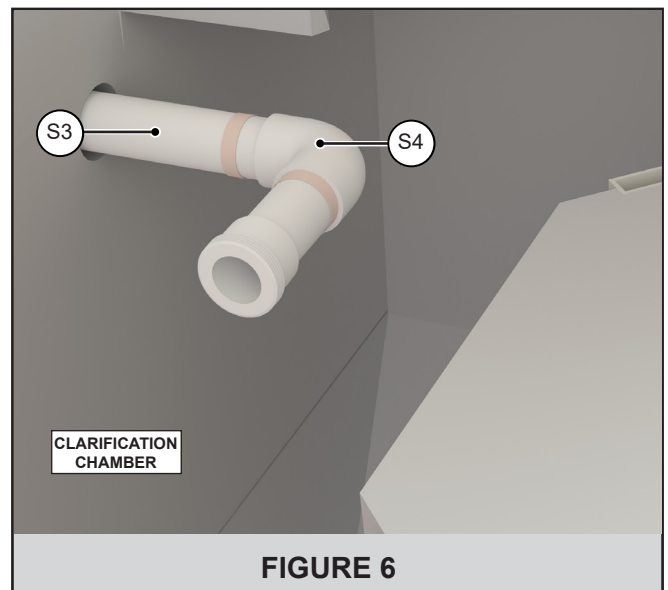

FIGURE 6

pump rests on the floor of the hopper as shown in Figure 7. Attach subassembly S4 to subassembly S6 at the union. Securely tighten the union by hand.

In the anoxic chambers:

5. Attach subassembly S7 to subassembly S8 at union as shown in Figure 7. Securely tighten union by hand.

6. Solvent weld subassembly S8 to subassembly S9 as shown in Figure 7. Insure yellow arrows are aligned.

7. Solvent weld subassembly S9 to subassembly S10 as shown in Figure 7. Insure green arrows are aligned.

8. Bend mixing bar assembly at flexible tubing and lower into the first anoxic chamber until mixing bar is positioned as shown in Figure 7. Attach subassembly S10 to subassembly S1 at union. Securely tighten union by hand.

9. Assemble remaining subassemblies S7 through S10 as described in previous steps. Bend the mixing bar assembly at flexible tubing and lower into the second anoxic chamber until mixing bar is positioned as shown in Figure 7. Attach subassembly S10 to subassembly S12 at union. Securely tighten union by hand.

10. Wire the recirculation pump female electrical connector. Unscrew the three captive stainless steel screws from the face of the female connector. They will stay in the body of the receptacle. Lift out the rigid internal receptacle body. Unscrew the compression nut on the strain relief connector. Insert the electrical service cable through the compression nut, compression ring and neoprene grommet. Strip the outer insulation back 1 1/4" on the underground electrical service cable and expose the three individual leads. Use extreme care to insure the insulation jackets on the individual black and white leads are not scarred or damaged while stripping the outer jacket.

11. Strip off the insulation jackets 7/16" from the ends of the individual black and white leads. Insert the black lead into the hole adjacent to the brass-colored screw and tighten the screw securely. Insert the white lead into the hole adjacent to the silver-colored screw and tighten the screw securely. Insert the bare copper ground lead into the hole that is adjacent to the green-colored screw and tighten the screw securely. Align the insert key on the receptacle body with the keyway molded into the rubber sleeve. Press the receptacle body into the sleeve and tighten the three stainless steel screws on the face of the connector. Press the neoprene grommet into the electrical connector and tighten the compression nut.

12. Plug the male connector on the recirculation pump power cord into the female connector.

13. Install each flow equalization device by sliding them into the tank receiving flanges in the clarification chamber as shown in Figure 8. Use the universal tool to insure each device is completely seated in the flange.

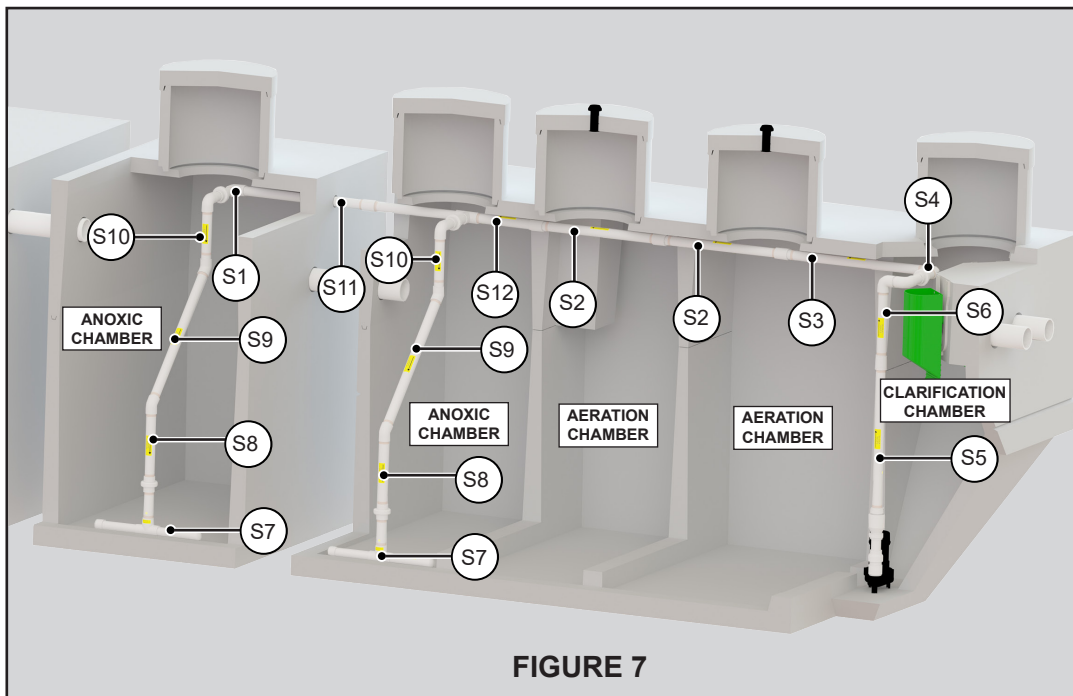

FIGURE 7

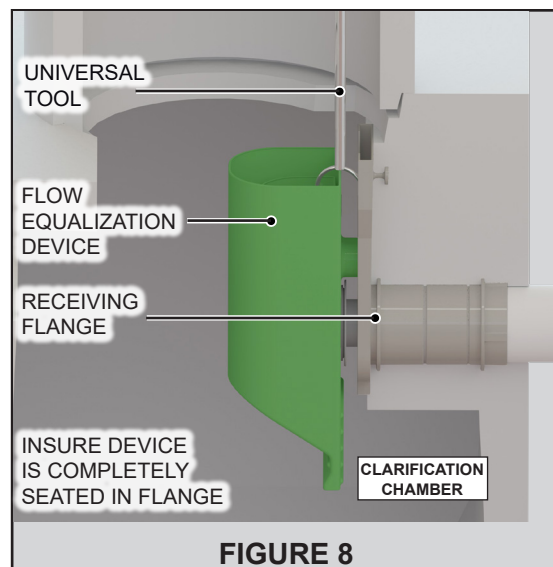

FIGURE 8

Completing the Installation

1. The control center should be wired for operation when the tank and underground electrical cables are installed. The control center should be located so that the red warning light can be seen and the audible alarm heard. The mounting

location should minimize exposure to direct sunlight, freezing rain or conditions that might prevent routine inspection or access. The control center should always be mounted out of the reach of children.

2. Remove the cover from the alarm wire junction box connected to the float switch. Solvent weld the junction box to the conduit containing the alarm leads, located in the second aeration chamber riser.
3. Reference Figure 9 for all wiring instructions. The black and white alarm wires contained in the junction box are provided to connect the float switch to the control center. Connect the black wire in the junction box to either alarm lead from the panel, and secure with a wire nut connector. Connect the white wire in the junction box to the remaining alarm lead from the panel, and secure with a wire nut connector.

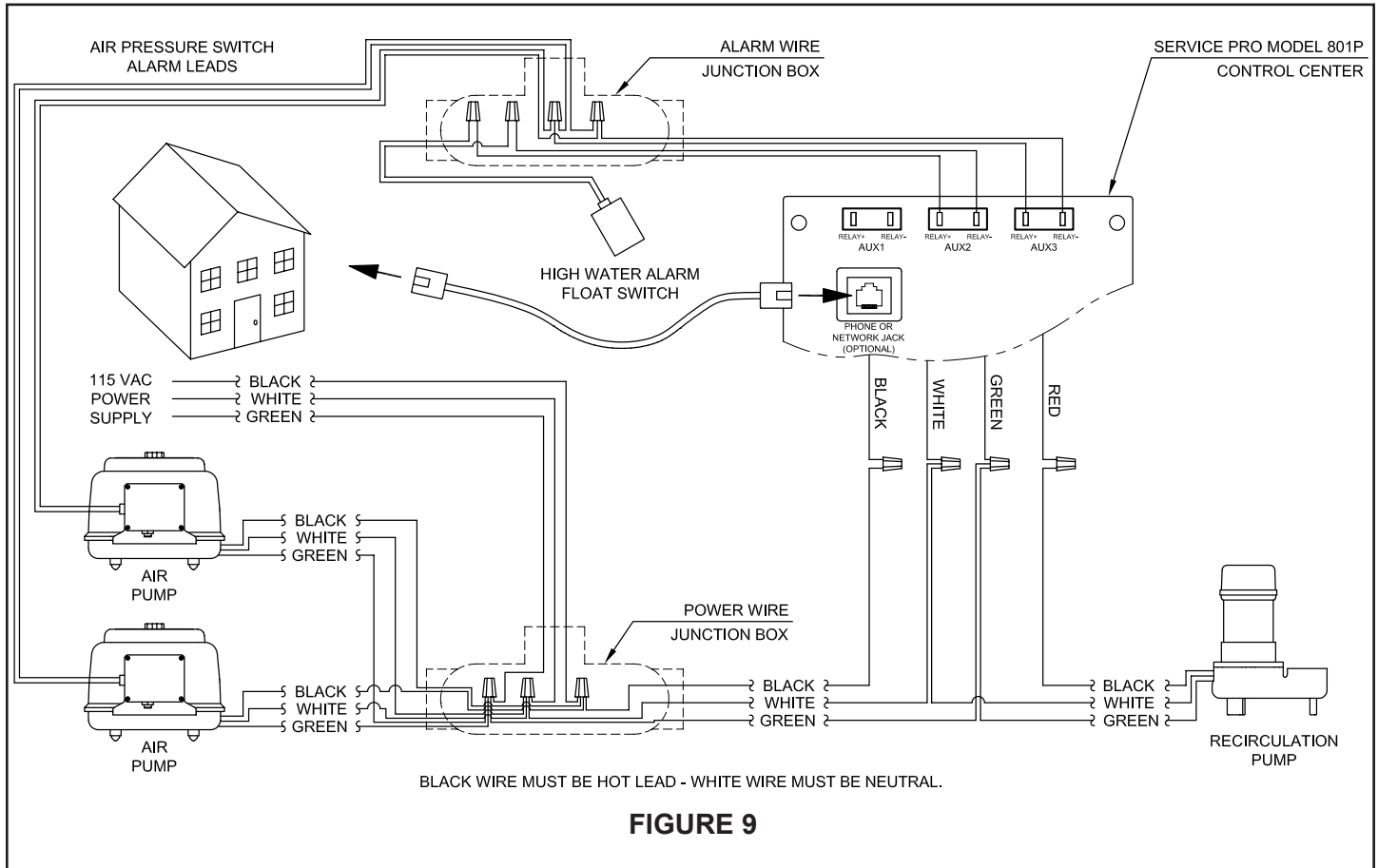

4. If the air pumps are installed in the aeration chamber risers, solvent weld the conduit connections for each pressure switch alarm cables to the appropriate junction box. Install two #16 AWG alarm wires from the junction box in the first aeration riser to the junction box in the second aeration chamber riser. Wire the two pressure switches in series by connecting one wire from the first pressure switch to one wire from the second pressure switch and secure with a wire nut connector. Connect the remaining alarm wire from the first pressure switch to either alarm lead from the panel, and secure with a wire nut connector. Connect the remaining alarm wire from the second pressure switch cable to the remaining alarm lead from the panel, and secure with a wire nut connector.
5. Reinstall and secure the cover on the alarm wire junction boxes. Plug any unused junction box openings.
6. Proceed to the control center. Detach the cover from the control center enclosure and remove the insert from the mounting posts. Set the control center insert aside. Remove the knockouts in the bottom of the enclosure and install a sealed conduit connector (distributor to provide) in each opening. Exposed wiring to or from the control center should always be encased in conduit. Mount the control center securely using masonry nails, wood screws or common nails as appropriate.
7. Use a dedicated 115 VAC, single-phase circuit at the main electrical service panel. A 15 amp circuit breaker is recommended (10 amp minimum). **CAUTION: MAKE SURE THIS CIRCUIT IS DE-ENERGIZED. CHECK IT WITH AN ELECTRICIAN'S TEST LIGHT BEFORE PROCEEDING. REMEMBER THAT OTHER CIRCUITS IN THE SERVICE PANEL MAY REMAIN ENERGIZED AS YOU ARE WORKING. USE ONLY TOOLS WITH INSULATED HANDLES, STAND IN A DRY LOCATION AND WORK WITH EXTREME CARE.**
8. Open the black electrical insulator on the back of the control center insert for access to power and alarm wiring connections.

9. Install a #14/2 AWG minimum cable with full-size center ground from the control center to the power wire junction box provided for connection to the control center. Wire from the dedicated circuit breaker in the main service panel to the power wire junction box. Use at least #14 AWG black copper wire. Connect the black wire from the main service panel to the black wires in the air pump power cables and the black wire to the control center. Secure with a wire nut connector.
10. Wire from the neutral in the main service panel to the junction box. Use at least #14 AWG white copper wire. Connect the white wire from the main service panel to the white wires from the air pump power cables and the white wire to the control center. Secure with a wire nut connector.
11. Connect the ground wire from the main electrical service panel to the non-insulated ground leads from the air pumps and the ground wire to the control center. Secure with a wire nut connector. **IMPORTANT:** Never allow the white neutral leads and the ground leads to be spliced together.
12. Install the cover on the junction box and proceed to the control center.
13. Connect the black wire from the junction box to the black wire on the control center. Secure with a wire nut connector.
14. Connect the black lead of the underground electrical cable from the recirculation pump to the red wire on the control center. Secure with a wire nut connector.
15. Connect the white wire from the junction box to the white wire from the recirculation pump and white wire on the control center. Secure with a wire nut connector.
16. Connect the ground wire from the junction box to the non-insulated ground lead from the recirculation pump and the green wire on the control center. Secure with a wire nut connector. **IMPORTANT:** Never allow the white neutral leads and the ground leads to be spliced together.
17. An auxiliary alarm input (AUX1) is available for connection of optional equipment such as an ultraviolet disinfection system, chemical detection system or effluent pump system. Refer to the Alarm Input section in the Service Pro Model 801P Installation and Operation Instructions for details regarding the connection of auxiliary equipment.
18. Connect the alarm leads from the high water float switch to the AUX2 RELAY terminals on the control center.
19. Connect the alarm leads from the two air pump pressure switches wired in series to the AUX3 RELAY terminals on the control center.
20. If the remote monitoring features of the control center will be utilized, run the telephone or network cable to the bottom of the control center enclosure. **IMPORTANT:** Never install the communication cable in a conduit with power lines.
21. Place the communication cable in the electrical grommet provided. The grommet snaps into the control center enclosure. Crimp the appropriate phone or network connector on the end of the communication cable. Plug the connector into the jack on the control center insert. Connect the other end to the telephone or network system.
22. Carefully form all wiring neatly into the lower part of the control center. Do not allow the wires to make contact with other electrical components in the control center. The conduit openings in the enclosure must now be sealed using expanding foam sealant (available from Norweco).
23. Close the black electrical insulator and snap the control center insert into position. Reinstall and close the control center cover. Secure it with the Norweco tamper evident seal.
24. Clearly label the dedicated circuit used for the Hydro-Kinetic system on the door of the main service panel. Replace the service panel deadfront and enclosure cover.

Final Check and System Startup

1. Place the dedicated circuit breaker for the Hydro-Kinetic system in the main service panel in the "on" position.
2. To commission the telemetry system, first insure the phone/network cable is properly installed. Place the control center power switch in the "off" position. While holding in the reset button, place the power switch in the "on" position. Continue to hold the reset button for 5 seconds. Release the reset button and allow the telemetry system up to 60 seconds to call out and complete the commissioning process. The phone/network light will illuminate during the call out process. If commissioning is successful, the alarm light will flash 5 short flashes and stop as verification. If commissioning is unsuccessful, refer to the Service Pro Model 801P Installation and Operation Instructions.
3. If no telemetry system is installed, press and hold the RESET button on the control center for 5 seconds. The audible alarm should sound and the alarm light should illuminate.

4. The system is operational once all installation and startup steps have been completed to this point. It will take 2 to 6 weeks for the system to reach biological maturity, depending upon system loading.

Routine Maintenance

The following should be performed every 12 months (or as required by your local governing regulations) by a qualified service technician:

1. If applicable, inspect the effluent discharge point to make sure there are no restrictions to the effluent flow. If restrictions are present, perform service as needed.
2. If effluent sampling is required, it is recommended that a proper sampling port be installed downstream of the Hydro-Kinetic system.
3. Inspect the vent caps, perimeter vents and air pumps for objects, plants, insects or debris that could impede the air intake. Remove these items if present.
4. Check the air pumps for proper operation. Check the air filters and clean or replace as required. Check the aeration chambers for odor. A musty odor indicates the presence of aerobic conditions essential for proper treatment. A septic odor indicates inadequate aeration, suggesting that the delivery of air into the aeration chamber has been restricted.
5. Check the aeration chambers and insure the diffuser assemblies are creating a rolling motion of the chamber contents. If a rolling motion is not visible, verify air pump operation. Remove and clean diffuser assembly if necessary.
6. Check the anoxic chambers and insure the mixing bars are operational. The recirculation pump operates on a pre-programmed on/off cycle, so press the reset button if necessary to verify operation.
7. Inspect the flow equalization devices. Rinse the design flow, sustained flow and peak flow ports with a garden hose and insure they are free of debris. Clean the flow ports with a brush if necessary.
8. Use the hopper scraping tool to gently scrape all surfaces of the clarification chamber hopper.
9. The settled solids should be pumped from the Bio-Film Reactor tanks to the pretreatment chamber. With the flow equalization device securely in place, install the outlet blocking tool into the clarifier outlet coupling prior to pumping. Place the intake of the service pump at the bottom of the influent chamber. Pump the contents from the bottom of the Bio-Film Reactor tank until the accumulated solids are withdrawn and the water level is below the bottom of the Bio-Film Reactor elements. Approximately 150 gallons will be removed during service. Rinse the media with a hose during tank pumping. After pumping, remove the outlet blocking tool and allow the Bio-Film Reactor tank to refill to normal operating level. Repeat these steps for the second Bio-Film Reactor tank. Never leave the Bio-Film Reactor tanks empty after pumping.
10. Inspect the system to determine if complete pumping may be required. See "System Pumping" section of this document.
11. Upon completion of the inspection, insure that all access covers are properly reinstalled. Any missing or damaged access covers should be immediately replaced. **CAUTION: MAKE SURE ALL ACCESS COVERS ARE REINSTALLED AND IN GOOD CONDITION.**
12. Approved Hydro-Kinetic system replacement parts are available from the authorized system dealer listed on the control center cover.

System Pumping

1. The Hydro-Kinetic system is a biological treatment device and will not require pumping as often as a septic tank. Pumping of the system will likely be required at 3 to 5 year intervals depending upon system usage, loading and treatment requirements. If pumping is required more frequently than every 2 years, there is an operational problem with the system and it should be evaluated in greater detail.
2. If the service technician suspects that the system may require pumping, a settleable solids test should be performed on a sample from each aeration chamber. The air pump must be removed from the aeration chamber riser to perform this test.
3. Immediately after removing air pump, dip a graduated cone or other clear container into the aeration chamber to a depth of 2½ feet. Set the container on a level surface and then allow the solids to settle for 30 minutes while you complete the service inspection. Do not disturb the container during the test.
4. After 30 minutes, read the level of solids and compare it with the total liquid volume in the container. Calculate the

percentage of settled solids volume (i.e. $\frac{1}{2}$ full of solids equals 50%). If the settled material contains large pockets of clear liquid, estimate the volume of these pockets and reduce the settled solids reading by that amount. A settled solids reading of up to 80% indicates no adjustments are necessary. A settled solids level greater than 80% in the aeration chamber indicates excessive solids and that the system should be pumped.

5. If it is determined that pumping is required, contact a tank pumping service licensed by the local regulatory agency. The septage or biosolids from the system must be removed and disposed of in a manner consistent with federal, state and local regulations. Advise the pumping service that they will be pumping approximately 3,000 gallons for the Model 3780L system, 4,000 gallons for the Model 4730L system, or 4,500 gallons for the Model 5670L system.
6. Turn off the air pumps and recirculation pump before tank pumping.
7. Remove the access cover from the aeration and clarification chambers. Unplug the air pumps and disassemble the unions located on the primary air connections. Remove the air pumps, primary air connections and support bases from the aeration risers. Use the universal tool to bend flexible diffuser tubing and remove the diffuser drop pipe assemblies. Connect the suction hose to the pump being used to evacuate the chamber.
8. Activate the pump and remove the first aeration chamber contents. Pump each aeration chamber from the top down, to remove biologically inactive material. Feed the hose down as the liquid is being evacuated from the aeration chambers. It is not necessary to wash down the sidewalls or tank bottom. Pump only 75% of the volume out of each aeration chamber to facilitate plant re-start. Once 75% of the volume has been removed from the first aeration chamber, repeat these steps for the second aeration chamber. Replace the diffuser drop pipe assemblies. Reinstall the support bases, primary air connections and air pumps. Reassemble the unions in the primary air connections and plug in the air pumps. Replace the access covers.
9. The Bio-Film Reactor tanks should be pumped after the aeration chambers. Remove the Bio-Film Reactor tank access covers. Lower the hose into the influent chamber of the first Bio-Film Reactor tank until it contacts the bottom of the tank. Withdraw the hose approximately 2 inches. Completely pump 100% of the contents from the chamber and rinse the media with a hose during tank pumping. Repeat these steps for the second Bio-Film Reactor tank. Replace the Bio-Film Reactor tank access covers.
10. Next, pump the anoxic chambers. Remove the anoxic chamber access covers. Use the universal tool to bend flexible mixing bar tubing and remove the mixing bar drop pipes to allow access for the suction hose. Lower the hose until it contacts the bottom of the tank. Withdraw the hose approximately 2 inches. Completely pump 100% of the contents from each anoxic chamber. Reinstall the mixing bar drop pipe assemblies and replace the access covers.
11. The final chamber to pump is the pretreatment chamber. Remove the pretreatment chamber access cover. Break up the scum mat to facilitate pumping. Lower the hose until it contacts the bottom of the tank. Withdraw the hose approximately 2 inches. Activate the pump and remove 100% of the chamber contents. It is not necessary to wash down the sidewalls or tank bottom. If solids are so concentrated that the suction hose cannot withdraw them, tank contents may be backflushed to break up the solid matter. Replace the pretreatment chamber access cover.
12. After pumping, refill all chambers to capacity with clean water. Return all plumbing and equipment to its properly installed location. Replace any access covers that were removed. Turn on power to the air pumps and the recirculation pump. Check for proper operation of all equipment.

Troubleshooting

This troubleshooting section provides efficient solutions to the most common problems encountered in the operation of the Hydro-Kinetic system.

Control Center Alarming

1. **Liquid in tank at level of high water alarm float:** system is flooded due to obstructions in the flow equalization devices, outlet, effluent line or disposal field. Determine cause and remove obstructions, or make repairs as required. Be sure to check effluent disposal system for proper operation.
2. **No rolling action in aeration chamber:**
 - Air pump is pumping air but there is an obstruction in the line between the air pump and diffuser: disassemble air line and remove obstruction.
 - Diffuser is plugged: remove and clean diffuser.
 - Air pump is not running: check power supply to air pump.
 - Air is escaping through a leak in the plumbing assembly between air pump and diffuser: identify and repair air leak. If necessary, remove the diffuser, diffuser drop pipe assembly and primary air assembly from the aeration chamber and use a soapy water solution to thoroughly coat the plumbing and check for bubbles. Repair air leak and retest.

3. **Air pump is running but does not pump air:** clean or replace air filter. Internal components are worn and the air pump is failing. Rebuild or replace the air pump. Contact the authorized Norweco representative for replacement components.
4. **No mixing action in anoxic chamber:**
 - Recirculation pump is operating but there is an obstruction in the line between the recirculation pump and mixing bar: disassemble mixing bar plumbing and remove obstruction.
 - Recirculation pump is not operating. Pump needs replaced. Contact the authorized Norweco representative for replacement components.
 - Mixing bar is plugged: remove and clean mixing bar.
 - Check valve is stuck in closed position: repair or replace check valve.

Septic Odor from System

1. **No power to air pumps:** check air pumps for proper operation. Insure the breaker is in the "on" position, the air pumps are plugged in and power is present (check with test light from Tool Kaddy)
2. **Insufficient air delivery to aeration chamber:** see "Control Center Alarming"
3. **Incomplete treatment due to hydraulic overloading:** see "Hydraulic Overloading of System"
4. **Water softener backwash discharging into system:** notify owner to remove backwash line from system
5. **Excessive solids in aeration chamber:** evaluate chamber and pump if necessary
6. **Excessive solids in anoxic chamber:** evaluate chamber and pump if necessary

Hydraulic Overloading of System

1. **Ground water entering tank through defective inlet or outlet seal:** excavate and repair seal
2. **Ground water entering system through crack in tank:** excavate and repair crack with hydraulic cement
3. **Ground water entering system through joint between riser and tank:** excavate and reseal joint with non-shrink grout or mastic
4. **Roofing down spouts, footer drains or floor drains tied into system:** notify owner to relocate connection downstream of system
5. **Check valve is stuck in closed position:** repair or replace check valve

Septic Odor from System

1. **No power to air pump:** check air pump for proper operation. Insure the breaker is in the "on" position, the air pump is plugged in and power is present (check with test light from Tool Kaddy)
2. **Insufficient air delivery to aeration chamber:** see "Control Center Alarming"
3. **Incomplete treatment due to hydraulic overloading:** see "Hydraulic Overloading of System"
4. **Water softener backwash discharging into system:** notify owner to remove backwash line from system
5. **Excessive solids in aeration chamber:** evaluate chamber and pump if necessary
6. **Excessive solids in anoxic chamber:** evaluate chamber and pump if necessary

Hydraulic Overloading of System

1. **Ground water entering tank through defective inlet or outlet seal:** excavate and repair seal
2. **Ground water entering system through crack in tank:** excavate and repair crack with hydraulic cement
3. **Ground water entering system through joint between riser and tank:** excavate and reseal joint with non-shrink grout or mastic

4. **Roofing down spouts, footer drains or floor drains tied into system:** notify owner to relocate connection downstream of system
5. **Check valve is stuck in closed position:** repair or replace check valve

Sampling

Proper sampling techniques are important to ensure that the results are representative of system performance. To ensure an accurate sample is collected, Norweco recommends that a sample port be installed immediately downstream of the treatment system. The sample port should allow a free falling sample to be collected. Sample ports should be cleaned before attempting to collect a sample.

If a sample port has not been provided, effluent from the Bio-Film Reactor should be evaluated by collecting a sample from the liquid above the Reactor Elements. The sample should be collected from 2-3" below the liquid surface to avoid collection of any floating solids that could interfere with results.

If a sample port has not been provided, effluent from the Phos-4-Fade filter should be evaluated by collecting a sample from the liquid above the Phos-4-Fade media. The sample should be collected from 2-3" below the liquid surface to avoid collection of any floating solids that could interfere with results.

Samples of the UV system effluent must be collected from a sample port installed downstream of the UV disinfection system.

If an influent sample is required, the influent sample should be collected from the pretreatment chamber.